

Renewable Energy Generation Using Vertical Axis Wind And Solar Panel for E-vehicle charging station

AniketMakode¹,Aamir Ail Asif Ali¹,Ajay Ukey¹,ArshadHasniainMansuri¹,Syed Salim¹ PramodGadge²

¹ Students Of Department Of Electrical Engineering

²FacultyAnjuman College Of Engineering & Technology Sadar, Nagpur

Abstract: The paper presents the idea about DC energy generation using renewable energy resources. The aim is to give basic idea about how the distributed energy generation can be utilized for the generation of electrical energy. Sufficient electrical energy in DC form can be obtained from the vehicles moving on the highways by using vertical axis wind turbine. At normal wind flow as well as during the flow of air due to moving vehicles the VAWT can generate power continuously. The rotor used is the savonius rotor with the upper and the lower parts of the Fins slightly modified to increase the obtained torque. Along with vertical axis wind turbine a solar panel is installed above it to extract the solar energy from the sun. The solar panel provides protection to the VAWT from the external environment. At night the electricity can be supplied to street light and during day as well as night the DC energy can be supplied for E vehicle charging station. Here the generator used is the permanent magnet DC generator and the energy generated can be stored in the battery

Keyword: Vertical axis wind turbine fabrication, solar panel, E-charging station, practical model.

I. Introduction

Due to limited amount of fuels present for the generation of electricity using conventional energy sources hence there is an increasing need of non-conventional energy sources. The hazardous effects of the conventional sources can be eliminated by using the non-conventional energy resources.

Here the wind energy as well as solar panel is used for the generation of electrical energy. It is pollution free, inexhaustible, less cost source of energy. The power available from the sun is approximately 1.8×10^{11} MW [1-7].

The vertical axis wind turbine and solar panel is being used together in the form of green source of DC electricity. In accordance with the electric demand, large amount of DC energy can be generated. The wind is caused by pressure difference between regions and the wind carries enormous quantity of energy thus a region that has strong wind for sufficient time period during the year can be used for the wind energy generation. As the paper consist of VAWT with solar panel on the highways, the wind at normal pressure as well as wind due to the moving vehicle boost the speed of rotation of the blades and hence the output is also increased. Here the output energy generated consist of energy generated due to VAWT as well as due to solar panel and this energy can be stored in the battery and can be given for the E-vehicle charging station[8-13].

The DC energy generated can be stored in the battery and the stored energy can be used for electric vehicle charging station. The electrical energy supplied to the charging station can be placed on the highways at some appropriate distance or can be given to any supplier. With the increase in the charging station, the selling of electrical vehicles will also increases and will increase direct and indirect employment. [14-17].

Description of purposed model: The actual model for the distributed energy generation is as shown below:



Photo:VAWT with solar panel

As shown in the fig above the three blades of the VAWT are made of aluminum material and are displaced 120 degree from each other. Thus the weight and cost of the blades are lesser and they have good strength and life. The shaft is made up of the poly vinyl chloride pipe and the blades are attached to the shaft. The length of the blade is about 1.1125 meter and the breadth is 0.3556 meter and the radius of the curved blade is 0.2794 meter. At the lower ends of the shaft, the gears are connected which is coupled with another gear of small size. And the generator is coupled with the small gear. The shaft is coupled with gear and gear is directly connected with the generator. The gear has the ratio of 1:9. The big gear has 134 tooth and small gear has 15 tooth, also the gear is made up of PVC material. Here a ball bearing is fixed at the upper side of the shaft and a roller bearing is used at the lower end of the shaft. The generator used is the Permanent magnet DC generator which can generate 64 Volts, 5 Ampere at 2200 RPM.

The output of from the generator is given to the battery for storage. The solar panel is installed above the vertical axis wind turbine system. The output can be increased by selecting the proper wattage of the solar panel act as a roof for the vertical axis wind turbine system so that it can provide protection from environment. The outputs of both are stored in battery

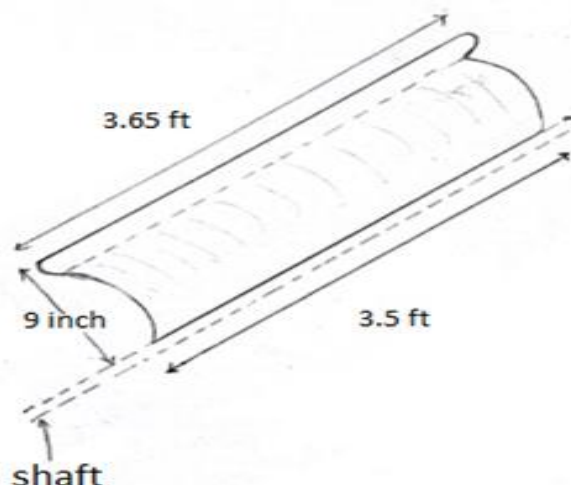

Calculation:

The availability of wind speed, the mechanical speed of the generator, the mechanical parameters are necessary for the design of the vertical axis wind turbine.

The kinetic energy of the air is given by the below equation :

$$K.E = \frac{1}{2}mV^2 \dots\dots\dots(1)$$

Where, “m” is the mass of the airflow.

“ K.E” is the kinetic energy

“ V” is the velocity of air

$$\text{Mass, } m = \rho AV \dots\dots\dots(2)$$

Where, “ ρ” is the density of air (1.225Kg/m²)

“A” is the area

The equation of available power is given by:

$$P_a = \frac{1}{2}C_p \pi R^2 \rho V^3 \dots\dots\dots(3)$$

Where “C_p “ is the power coefficient

$$C_p = \frac{\text{Mechanical power generated by the turbine}}{\text{Available power from the wind}}$$

For the vertical axis wind turbine the area is given by the following eqn:

$$A = 2 * H * R \dots\dots\dots(4)$$

Where” R” is the radius of the turbine

“ H” is the height of the turbine blades. [18-25]

Length of blade=3.65 feet =1.1125 m

Diameter =0.2794 m

Therefore A=2RH=0.31 m²

$$C_p = \frac{P_m}{P_a} = 0.5609$$

Survey report and analysis: The proposed model was taken to the Nagpur Mumbai Highway (NH6) and the survey was carried out. At various places the wind speed at different height were noted and then the voltage at the particular wind speed was measured. The table 1 shows the wind speed, speed of shaft and the voltage obtained.

Table no.1: relation between wind speed and shaft speed and voltage

Sr.no	Wind speed (m-s)	Speed of shaft (RPM)	Voltage (volt)
1	2.6	47.7	10.2
2	3	55.9	11.4
3	3.5	60.7	13.8
4	3.8	66.6	14.4
5	4	71.8	15.2
6	4.4	78.8	17
7	4.8	85.5	18.6
8	5.1	87	19.6

The internal resistance of PMDC generator =13.8 ohm

$$P_{avg} = 15.025 * 15.025 / 13.8 = 17.00 \text{ VA}$$

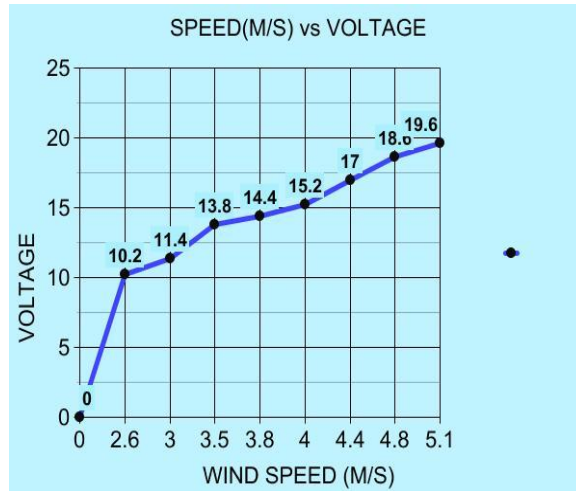

Graph (1). Variation between wind speed and voltage

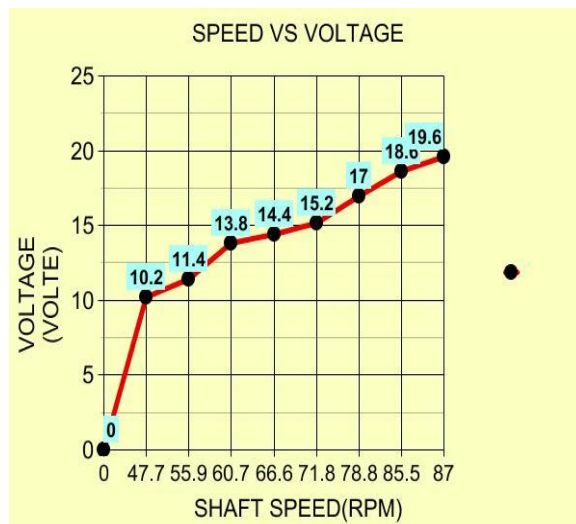

Graph (2). Variation between shaft speed and voltage

Table no.2: relation between wind speed and power

sr.no	wind speed (m-s)	Volatge (volt)	Current (amp)	Power (watt)
1	2.6	10.2	0.739	7.53
2	3	11.4	0.831	9.41
3	3.5	13.8	1.00	13.8
4	3.8	14.4	1.043	15.02
5	4	15.2	1.101	16.74
6	4.4	17	1.230	20.94
7	4.8	18.6	1.348	25.06
8	5.1	19.6	1.420	27.837
Average	3.42	15.025	1.08	17.00

The solar panel used in this model is of 110VA .By selecting the proper wattage of the solar panel the output can be increased.Hence with this solar panel the energy available on highway can be utilised.

II. Conclusion

The distributed energy generation using vertical axis wind turbine and solar panel can be utilised for the generation of green, non polluting energy on the highways.Hence with this the abundant solar and wind power on the highways can be utilised which otherwise could have been wasted. The VAWT can generate energy from vanes of air from both the directions. Vehicles running from both side form air force on the highway at major level. The average wind speed on highway is much more greater than normal air in coastal

areas. Solar energy can generate in only 10 to 12 hours in a day but VAWT would generate 22 to 24 hours in a day. Hence the energy generated can be stored in the battery and then it can be given for highway lighting at night and for E-vehicles charging station at night as well as during day hours.

Reference

- [1]. Vertical axis wind turbine for highways application [vol2(10,2016)], issn 2454-1362 imperial journal of interdisciplinary research (IJIR) prof.arun kulkarni pune, india
- [2]. M.K. Sharma "The study of wind energy potential from highway". In International Journal of Engineering Research and Technology, 2012.
- [3]. J Berrocal, Brian Dolan, M Tangredi "Design of Vertical Axis Wind Turbine to Power Led Street Lights".
- [4]. M.C.Claessens "testing and design of aerofoils for Application in Small Scale Vertical Axis Wind Turbines
- [5]. Guoying Feng, Zhinhang Liu, Bao Daorina, Zheng Gong", " Experimental Research on Vertical Wind Turbine", 2009 [9] www.Wikipedia.com
- [6]. Peter J. Schubel and Richard J. Crossley", "Wind Turbine Blade Design" 2012
- [7]. A. Al Tarabsheh, I. Etier, H. Fath, A. Ghazal, Y. Morci, M. Asad, A. El Haj, "Performance of Photovoltaic Cells in Photovoltaic Thermal (PVT) Modules", IET Renewable
- [8]. A. Makki, S. Omer, H. Sabir, "Advancements in hybrid photovoltaic systems for enhanced solar cell performance", Renewable and Sustainable Energy Reviews, Vol.41, pp: 658–684, 2015
- [9]. A. Fathima, K. Palanisamy, "Optimization in microgrid with hybrid energy systems – A review", Renewable and Sustainable Energy Reviews, Vol. 45, pp: 431–446, 2015
- [10]. I. K. Yokoyama, R., "Multiobjective optimal unit sizing of hybrid power generation systems utilizing photovoltaic and wind energy" Int. Journal of Solar Energy Engineering.
- [11]. L. Theodore, "Heat transfer applications for the practicing engineer". New Jersey: John Wiley & Sons; 2011
- [12]. C. Rajoria, S. Agrawal, G. Tiwari, "Overall thermal energy and exergy analysis of hybrid photovoltaic thermal array". Sol Energy, Vol. 86, pp: 1531–1538, 2012.
- [13]. R. Daghigh, M. Ruslan, K. Sopian, "Advances in liquid based photovoltaic/ thermal (PV/T) collectors". Renewable Sustainable Energy Review, Vol.15, Issue 8, pp: 4156–70.
- [14]. Standards Coordinating Committee 21, "IEEE Std 1547-2003, IEEE standard for interconnecting distributed resources with electric power systems," USA: The Institute of Electrical and Electronics Engineers, Inc., 28 July 2003.
- [15]. BEBP World Energy Statistics 2010[R]. www.bp.com/statistica Vreview, 2010.
- [16]. Ahmed Yousuf Saber, Ganesh Kumar Venayagamoorthy, "One Million Plug-in Electric Vehicles on the Road by 2015," IEEE Conference on Intelligent Transportation Systems, St. Louis, MO, USA, 2009.
- [17]. Basu M, Gaughan K, Coyle E, "Harmonic Distortion Caused By EV Battery Chargers in the Distribution System Network and Its Remedy," Universities Power Engineering Conference, 2004. UPEC2004, The 39th International 2004: 869–873.
- [18]. Paul D., Sandra E., Andreas S., "Simulation and control of direct driven permanent magnet synchronous generator (PMSG)" 9999
- [19]. Belakehal S., Benalla H., and Bentounsi A. "Power maximization of small wind system using permanent magnet synchronous generator" Revue des énergies renouvelables Vol.12 N°2 (2009)
- [20]. Aravind CV, Rozita T, Grace "Universal Computer Aided Design for Electrical Machine Design" 8th International Colloquium on Signal Processing and applications, Kuala Lumpur, March 2012
- [21]. Grace I, Aravind CV, Rozita T, Samuel Bright "CAD for rotary reluctance motors" Proceedings of IEEE STUDENT 2011 Conference, Malaysia, 20-21 oct 2011
- [22]. Norhisam, M., Syafiq, M.; Aris, I.; Abdul, R.J. Design and analysis of a
- [23]. single phase slot-less permanent magnet generator. In Proceedings of the IEEE 2nd International Power and Energy Conference, 2008, art. no.4762636, pp. 1082-1085. 2012 IEEE International Conference on Power and Energy (PECon), 2-5 December 2012, Kota Kinabalu Sabah, Malaysia 103
- [24]. Jan V., Andre M., and Alberto R., "Optimization of a wind turbine using permanent magnet synchronous generator".
- [25]. Raju. A.B., Fernandes B.G., Kishore C., "Modelling and simulation of a grid connected variable speed wind energy conversion system with low cost power converters" Renewable energy & power Quality Journal, No.1, (2003).
- [26]. Video link of highway survey :<https://youtu.be/P4Ga7U8UJyY>